

Rev:	Date	By	Chk	Description
A.1	2/25/13	PJE	AKH	ECO 0045

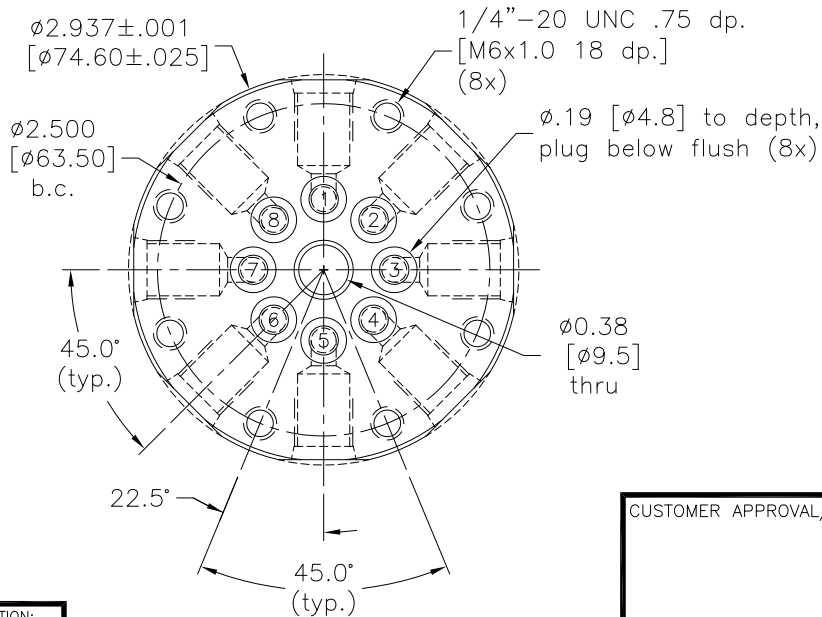
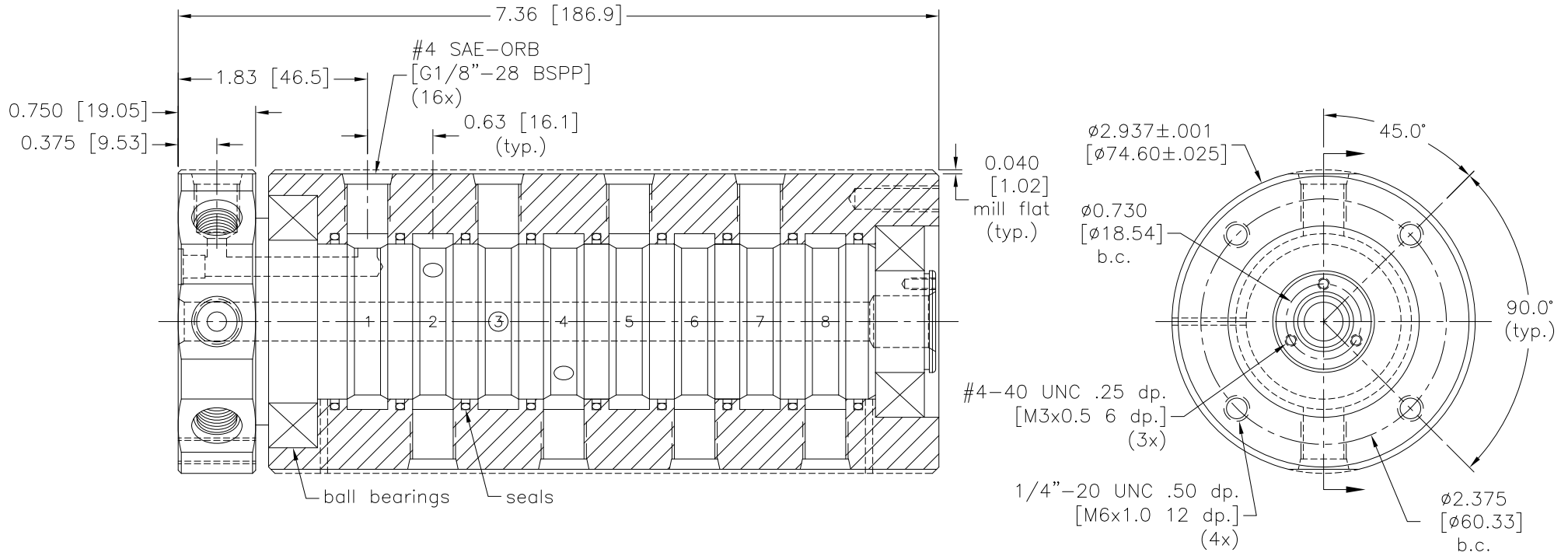

**Notes:**

1. Union will be rotated for seal break-in and static air tested.
2. Media must be filtered, clean and free of abrasive content or reduced union life will result.
3. Metric connections and threads available by using SEM in place of SE in the series designation prefix.
4. See SHEET 2 for product options.

Drawn	JSM	6/1/03
Checked	PJE	11/28/05
Checked	PJE	11/24/08

TOLERANCE EXCEPT AS NOTED	
X.X	±.125
X.XX	±.015
X.XXX	±.005
ANGLES	± 0.5°

SHAFT MTL/PLTING:  
CARBON STL  
58-62 Rc  
BLK OXIDE

HOUSING MTL/PLTING:  
CARBON STL  
BLK OXIDE



CUSTOMER: STOCK

P/N: SE(M)-1181

REV: A.1

CUSTOMER APPROVAL/DATE:

THIS DOCUMENT CONTAINS INFORMATION WHICH IS PROPRIETARY TO DYNAMIC SEALING TECHNOLOGIES, INC. (DSTI) NO REPRODUCTION OR PUBLICATION OF THIS DOCUMENT OR IT'S CONTENTS, IN WHOLE OR PART, SHALL BE MADE WITHOUT THE WRITTEN CONSENT FROM DSTI.

THIRD ANGLE PROJECTION:

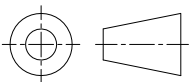

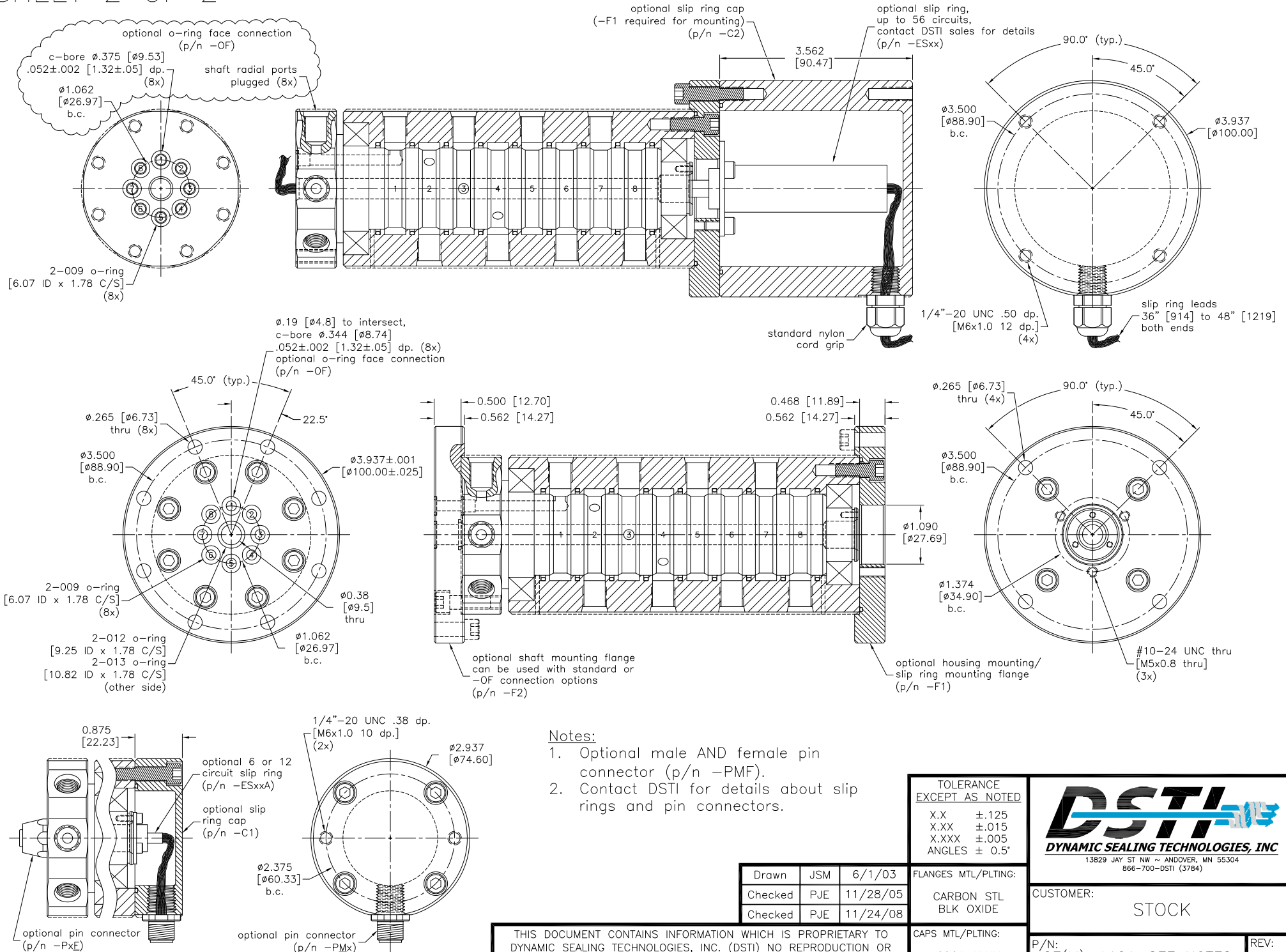

**Notes:**

1. Optional male AND female pin connector (p/n -PMF).
2. Contact DSTI for details about slip rings and pin connectors.

TOLERANCE EXCEPT AS NOTED	
X.X	$\pm .125$
X.XX	$\pm .015$
X.XXX	$\pm .005$
ANGLES	$\pm 0.5^\circ$



Drawn	JSM	6/1/03
Checked	PJE	11/28/05
Checked	PJE	11/24/08

FLANGES MTL/PLTNG:  
CARBON STL  
BLK OXIDE

CUSTOMER:  
STOCK

CAPS MTL/PLTNG:  
6061 ALUM  
BLUE ANODIZE

P/N:  
SE(M)-1181-SEE NOTES

REV:  
A.1

THIS DOCUMENT CONTAINS INFORMATION WHICH IS PROPRIETARY TO DYNAMIC SEALING TECHNOLOGIES, INC. (DSTI) NO REPRODUCTION OR PUBLICATION OF THIS DOCUMENT OR IT'S CONTENTS, IN WHOLE OR PART, SHALL BE MADE WITHOUT THE WRITTEN CONSENT FROM DSTI.